

PARTS USED FOR S/S SUMP INSTALL

DESCRIPTION	PART #	QUANTITY
STAINLESS STEEL FRAME	DSFF024-2400	1
F.G. GRATE 23" W X 23" B.B.	DSG2323	1
1/4" B. H. CAP SCREW 1 1/2" LG.	SSBS025-1500L	4
ANTI-SEIZE LUBRICANT	SBANTI-SEIZE	1

PARTS USED FOR CONCRETE SUMP INSTALL

DESCRIPTION	PART #	QUANTITY
ANTI-ENTRAPMENT COVER	DSFF024-2400	1
F.G. GRATE 23" W X 23" B.B.	DSG2323	1
1/4" S/S DROP-IN ANCHOR	SBCA025-316L	4
1/4" B. H. CAP SCREW 1 1/2" LG.	SSBS025-1500L	4
ANCHOR SETTING TOOL	SBCA025-TOOL	1
ANTI-SEIZE LUBRICANT	SBANTI-SEIZE	1

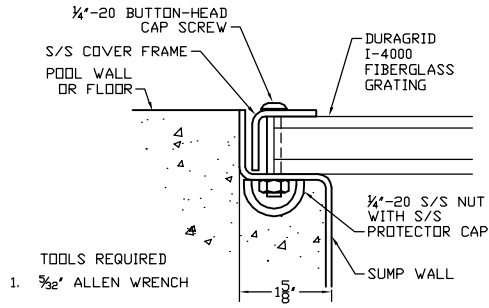

STAINLESS STEEL SUMP INSTALLATION

SUMP MUST MEET DIMENSIONS SHOWN IN FIGURE 2 OF THE ASME A112.19.8-2007 CODE

THESE INSTALLATION INSTRUCTIONS ARE FOR THE MANUFACTURER'S RECOMMENDED STAINLESS STEEL SUMP MODEL # SUF24X24-X (X=PIPE SIZE)

1. GRATE SHOULD BE IN PLACE WHEN CONCRETE IS POURED AROUND THE SUMP TO PREVENT PRESSURE FROM THE CONCRETE DISTORTING THE SUMP WALL AND MOVING THE MOUNTING LOCATIONS
2. FRAME DOES NOT NEED A SEPARATE GROUNDING WIRE, IT WILL GROUND THROUGH THE HARDWARE (S/S SUMP SHOULD BE GROUNDED) CUT OFF GROUNDING WIRE FOR S/S SUMP APPLICATIONS ONLY
3. APPLY ANTI-SEIZE LUBRICANT TO THE PROVIDED BUTTON-HEAD SCREWS
4. PUT ASSEMBLY IN PLACE AND ATTACH WITH BUTTON-HEAD SCREWS, CARE SHOULD BE TAKEN TO MAKE SURE THE FIBERGLASS GRATE IS CENTERED UNDER THE S/S FRAME, A 3/32" ALLEN WRENCH IS NEEDED (TORQUE SCREWS TO 5 FOOT POUNDS)

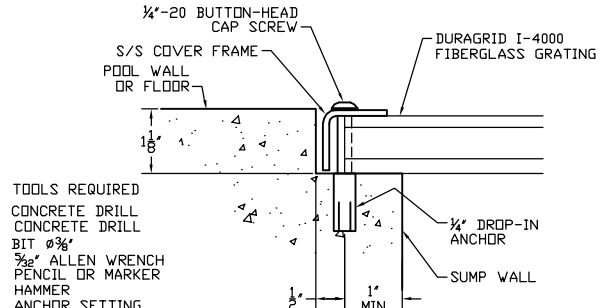

CONCRETE SUMP INSTALLATION WITH LEDGE

SUMP MUST MEET DIMENSIONS SHOWN IN FIGURE 2 OF THE ASME A112.19.8-2007 CODE

THESE INSTALLATION INSTRUCTIONS ARE FOR A CONCRETE FIELD FABRICATED SUMP

1. SUMP NEEDS TO HAVE A CONCRETE LEDGE WITH OUTSIDE DIMS. 24" X 24"
2. PUT ASSEMBLY IN PLACE AND MARK ALL HOLE LOCATIONS, IF POSSIBLE USE A 1/2" CONCRETE BIT AND DRILL A PILOT HOLE 1" DEEP WITH COVER IN PLACE
3. DRILL 3/8" HOLE IN ALL LOCATIONS 1" DEEP (CHECK MARKS AFTER EACH HOLE)
4. INSERT 1/4" S/S DROP-IN ANCHORS, MAKE SURE THEY ARE FLUSH OR SLIGHTLY BELOW CONCRETE, SET THE ANCHOR BY STRIKING THE INTERNAL PIN WITH THE PROVIDED SETTING TOOL AND A HAMMER
5. ATTACH THE GROUND WIRE TO A SUITABLE GROUND (IF REQUIRED)
6. APPLY ANTI-SEIZE LUBRICANT TO THE PROVIDED BUTTON-HEAD SCREWS
7. PUT ASSEMBLY IN PLACE AND ATTACH WITH BUTTON-HEAD SCREWS, CARE SHOULD BE TAKEN TO MAKE SURE THE FIBERGLASS GRATE IS CENTERED UNDER THE S/S FRAME, A 3/32" ALLEN WRENCH IS NEEDED (TORQUE SCREWS TO 5 FOOT POUNDS)

**DSF24X24 ANTI-ENTRAPMENT GRATE INFORMATION
 MAXIMUM FLOW RATING IS 555 GPM - FLOOR INSTALL ONLY
 READ AND UNDERSTAND COMPLETELY BEFORE INSTALLATION
 FAILURE TO DO SO CAN CAUSE SEVERE INJURY AND/OR DEATH**

1. THIS GRATE WAS TESTED AND IS CERTIFIED TO ASME/ANSI A112.19.8a-2008 STANDARDS
2. MANUFACTURED BY EUREKA MANUFACTURING, MODEL NUMBER DSF24X24, MAXIMUM FLOW RATING IS 555 GPM
3. CLASSIFICATION IS "SUBMERGED SUCTION OUTLET" AND IS APPROVED FOR FLOOR INSTALLATIONS ONLY
4. THIS GRATE IS APPROVED TO ONLY FIT INTO THE MANUFACTURER RECOMMENDED STAINLESS STEEL SUMP OR A CONCRETE SUMP THAT CONFORMS TO THE DIMENSIONS IN FIG 2 OF THE ASME A112.19.8-2007 CODE, ANY OTHER APPLICATION MUST BE DESIGNED AND APPROVED BY A REGISTERED DESIGN PROFESSIONAL
5. DO NOT LOCATE SUCTION OUTLET ON SEATING AREA OR ON THE BACK RESTS FOR SUCH SEATING AREAS
6. REPLACE HARDWARE AND GRATE ASSEMBLY WITHIN 8 INSTALLED YEARS
7. WHEN TWO OR MORE SUCTION FITTINGS ARE USED ON A COMMON SUCTION LINE THEY MUST BE SEPARATED BY A MINIMUM OF 3' (91.44 CM)
8. IN THE EVENT OF ONE SUCTION OUTLET BEING COMPLETELY BLOCKED, THE REMAINING SUCTION OUTLETS SERVING THE SYSTEM SHALL HAVE A FLOW RATING CAPABLE OF THE FULL FLOW OF THE PUMP(S) FOR THE SPECIFIC SUCTION SYSTEM
9. THE SUCTION OUTLET SHOULD BE CHECKED FOR DAMAGE OR TAMPERING BEFORE EACH USE OF THE FACILITY
10. MISSING, BROKEN, OR CRACKED SUCTION OUTLETS SHALL BE REPLACED BEFORE USING THE FACILITY
11. LOOSE SUCTION OUTLETS SHALL BE REATTACHED OR REPLACED BEFORE USING THE FACILITY
12. WHEN REPLACING THE PUMP, MAKE SURE NOT TO EXCEED THE MAXIMUM FLOW RATE FOR THE SUCTION OUTLET

Facility		Signature		Date	
ANTI-ENTRAPMENT GRATE INSTALL		Scale NONE		Drawing No. DSF24X24	
Date 7-13-09	Drawn AKP	Chk.	Rev. NONE	INSTALL PAGE 1 OF 2	

13. SERVICE AND WINTERIZING INSTRUCTIONS: CHECK GRATE DAILY WHILE POOL IS IN USE, IF GRATE SHOULD BECOME LOOSE TIGHTEN SOCKET-HEAD SCREWS OR REINSTALL
14. ACCEPTABLE CONNECTING PIPE SIZES ARE 6", 8", AND 10"
15. DO NOT EXCEED THE MAXIMUM ALLOWABLE FLOW OF 555 GPM
16. READ, THEN KEEP THESE INSTRUCTIONS FOR FUTURE REFERENCE

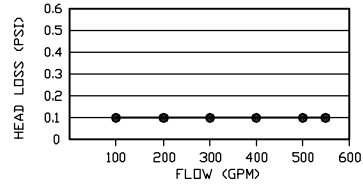

THIS ANTI-ENTRAPMENT GRATE ASSEMBLY SHALL BE GUARANTEED BY THE MANUFACTURER FOR WORKMANSHIP AND MATERIALS FOR A PERIOD OF ONE (1) YEAR. GRATE IS MORE SUSCEPTIBLE TO CORROSION IF IT IS NOT GROUNDED. CLEANING THE GRATE TO PRESERVE THE FINISH MAY BE REQUIRED AND IS NOT COVERED UNDER THE WARRANTY. THE WARRANTY WILL NOT INCLUDE ABUSIVE OR IMPROPER TREATMENT OF THE GRATE DURING INSTALLATION OR UNDER OPERATION. THE COMPANY SHALL HAVE NO LIABILITY TO CORRECT ANY DAMAGE CAUSED BY NEGLIGENCE, MISUSE, OR ANY OTHER EXTERNAL CAUSES. THE BUYER'S SOLE REMEDY IS REPLACEMENT OF THE PRODUCT. THERE IS NO REMEDY FOR OTHER DAMAGES INCLUDING CONSEQUENTIAL DAMAGES FOR INSTALLATION COSTS, LOST PROFITS, OR OTHER DAMAGES.

POOL INFORMATION

1. NUMBER OF SUMPS ON THIS SUCTION LINE _____
2. SIZE OF SUMP OPENING (S) _____
3. IS THE SUMP (S) UNDER POSITIVE SUCTION OR GRAVITY FLOW _____
4. DOES THE SYSTEM HAVE A VACUUM RELEASE SYSTEM _____
5. SIZE AND LOCATION OF PIPE IN THE SUMP _____
6. DISTANCE FROM POOL FLOOR TO THE SUCTION PIPE INLET (SEE BELOW) _____
7. GPM NEEDED ON THIS SUCTION LINE _____
8. DISTANCE BETWEEN PIPE CENTERLINES (IF MULTIPLE DRAINS) _____
9. PLEASE PROVIDE ANY ADDITIONAL INFORMATION THAT MAY BE NECESSARY OR HELPFUL _____

SUMP OPTIONS

1. FIELD BUILT SUMP (INCLUDES EXISTING SUMPS)

1.5 TIMES PIPE DIA.

1.5 TIMES PIPE DIA.

-DRAWINGS REFLECT ASME A112.19.8a-2008 STANDARD, ADDITIONAL RESTRICTIONS MAY APPLY
2.

1.5 TIMES PIPE DIA.

-ADD SUCTION DIVERTER
 -CONTACT YOUR SUPPLIER FOR MORE INFORMATION
 -DETAILED SUMP INFORMATION WILL BE NEEDED

-IF YOUR SUMP DOES NOT MEET THE REQUIREMENTS DESCRIBED IN FIG. 1 IT MAY BE POSSIBLE TO ADD A SUCTION DIVERTER (DEPENDING ON YOUR SUMP CONFIGURATION) FOR MORE INFORMATION ON THIS OPTION CONTACT YOUR SUPPLIER, A LICENSED DESIGN PROFESSIONAL OR CONSUMER PRODUCT SAFETY COMMISSION - WWW.CPSC.GOV
 THE AMERICAN SOCIETY OF MECHANICAL ENGINEERS - WWW.ASME.ORG
3. CONTACT A LICENSED DESIGN PROFESSIONAL TO EVALUATE AND GIVE RECOMMENDATIONS FOR COMPLIANCE
4. CONTACT YOUR SUPPLIER FOR THE MANUFACTURER'S RECOMMENDED SUMP

ANY RECOMMENDATIONS ARE BASED ON INFORMATION RECEIVED. THE MANUFACTURER CANNOT BE RESPONSIBLE FOR MISINFORMATION. MANUFACTURER DOES NOT ASSUME LIABILITY FOR THE SUMP, INSTALLATION, OR MISUSE OF THE PRODUCT.

SELLER MAKES NO OTHER EXPRESS OR IMPLIED WARRANTY REGARDING THE USEFUL LIFE OF THE PRODUCT OR REGARDING THE OPERATION, USE, OR PERFORMANCE OF THE PROPERTY. SELLER SHALL HAVE NO LIABILITY TO THE BUYER OR ANY PERSON FOR ANY CLAIM, LOSS, DAMAGE, OR EXPENSE (INCLUDING ATTORNEYS FEES) OF ANY KIND OR NATURE, WHETHER SPECIAL, CONSEQUENTIAL, ECONOMIC OR OTHERWISE, CAUSED OR ALLEGED TO BE DIRECTLY, INDIRECTLY, INCIDENTALY, OR CONSEQUENTIALY BY THE PRODUCT OF ANY PART THEREOF OR BY THE INADEQUACY OF THE PRODUCT WHATSOEVER OR ANY RECOMMENDATIONS GIVEN REGARDING THE PRODUCT AND ITS USE.

Facility		Signature		Date
ANTI-ENTRAPMENT GRATE INSTALL		Scale NONE		Drawing No. DSF24X24 INSTALL PAGE 2 OF 2
Date 7-13-09	Drawn AKP	Chk.	Rev. NONE	